

SIDE VIEW

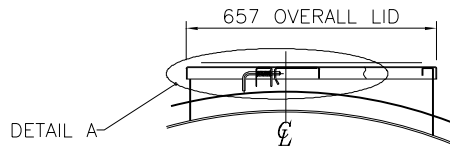

VIEW ON REAR END

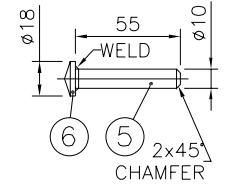

PIVOT PIN DETAIL

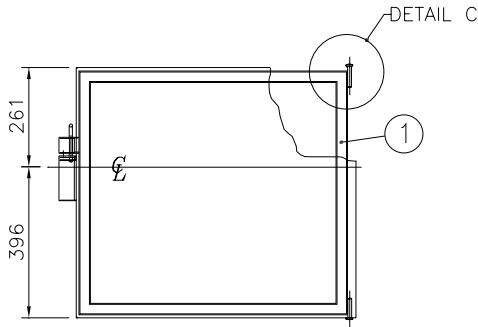

PLAN VIEW

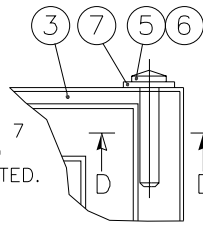

DETAIL C

WELD WASHER ITEM 7 IN PLACE ONCE LID IS POSITIVELY LOCATED.

WELD BOTTOM OF PIVOT PIN WHEN LID IS CLOSED, WELD ON TOP WHEN LID IS OPEN. WELD FULL LENGTH ON TOP AND BOTTOM.

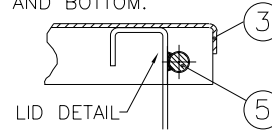

SECTION D-D

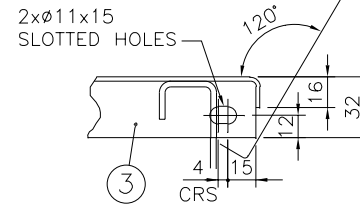

DETAIL E

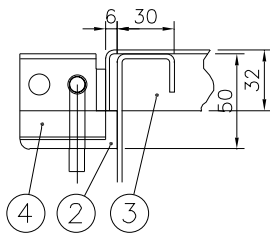

SECTION B-B

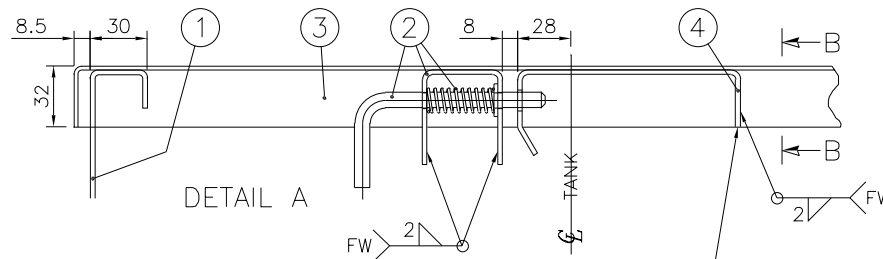

DETAIL A

POSITION FLUSH WITH BOTTOM EDGE OF SPILLBOX LID

MATERIAL SPECIFICATION						
E	ASTM A240 304	Z	S/S 304			
PARTS LIST						
No.	QTY	MAT	STOCK CODE	DESCRIPTION	DIMENSIONS	REFERENCE
1				TOP DISCHARGE SPILLBOX		SEE DRAWING LIST
2			8099	LOCKING PIN		
3	1	E	-	SPILLBOX LID	PLATE 2x713x775	
4	1	E	-	HANDLE	PLATE 2.5x45x175	
5	2	Z	-	PIVOT PIN	Ø10 x 55LONG	
6	2	Z	-	PIVOT PIN RETAINER	Ø18 x 3THK	
7	2	Z	-	FLAT WASHER	M10	

NOTE:

- QUANTITIES GIVEN ARE FOR 1-OFF T.C. 50-OFF TANK CONTAINERS IN CONTRACT

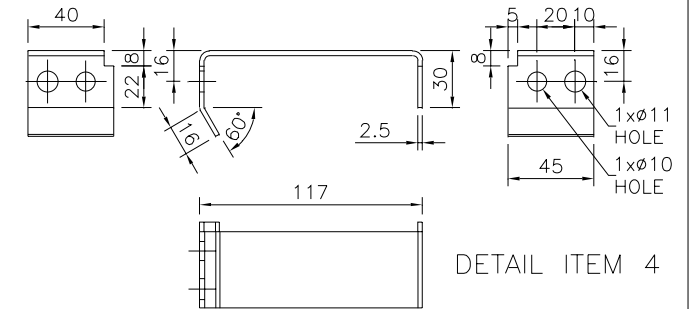

DETAIL ITEM 4

**CONSANI ENGINEERING (PTY) LTD**  
 ELSIES RIVER, CAPE SOUTH AFRICA  
 TEL. 590-3400 FAX. 591-2825

INTERMODAL CONTAINERS

THIS DRAWING AND INFORMATION IS THE PROPERTY OF CONSANI ENG. (PTY) LTD AND MAY NOT BE REVEALED TO ANY THIRD PARTY WITHOUT OUR WRITTEN PERMISSION.  
 CAD: 24422042

REVISION B				REVISION A				DRAWING APPROVAL			REQUIRED TOLERANCE		NOMINAL DIMENSIONS (SHORT SIDE OF TRIANGLE)						NOMINAL DIMENSIONS									
AUTHORITY	SIGN.	DATE	DESCRIPTION	AUTHORITY	SIGN.	DATE	DESCRIPTION	AUTHORITY	SIGNATURE	DATE	DEGREES & MINUTES	MM/M	ABOVE 0 TO 315	ABOVE 315 TO 1000	ABOVE 0 TO 315	ABOVE 315 TO 1000	ABOVE 0 TO 120	ABOVE 120 TO 315	ABOVE 315 TO 1000	ABOVE 1000 TO 2000	ABOVE 2000 TO 4000	ABOVE 4000 TO 8000	ABOVE 0 TO 120	ABOVE 120 TO 315	ABOVE 315 TO 1000	ABOVE 1000 TO 2000	ABOVE 2000 TO 4000	ABOVE 4000 TO 8000
DRAWN				DRAWN				DESIGN			A	± 20' ± 15' ± 10'	± 6 ± 4.5 ± 3	± 1 ± 1 ± 2 ± 3 ± 4 ± 4 ± 6														
DESIGN				DESIGN				QUALITY ASSURANCE			B	± 45' ± 30' ± 20'	± 13 ± 9 ± 6	± 2 ± 2 ± 3 ± 4 ± 6 ± 8 ± 10														
QUALITY ASSURANCE				QUALITY ASSURANCE				CONTRACTS			C	± 1' ± 45' ± 30'	± 18 ± 13 ± 9	± 3 ± 4 ± 6 ± 8 ± 11 ± 14 ± 18														
CONTRACTS				CONTRACTS				INSPECTION AUTHORITY			D	±1'30' ±1'15' ± 1'	± 26 ± 22 ± 18	± 4 ± 7 ± 9 ± 12 ± 16 ± 21 ± 27														
INSPECTION AUTHORITY				INSPECTION AUTHORITY				CLIENT			DIN 8570 PART 1						FROM 0-30 TOLERANCE ±1 DIN 8570 PART 3											

TOP DISCHARGE SPILLBOX LID DETAIL						
CLIENT	OCI	SCALE	1:10	DRAWING NUMBER		REVISION
WORKS ORDER	2442	DRAWN	RASHAAD	2442-02-2042		0
		CHECKED				
		DATE	13/02/02			